

## 5.8 cu. ft. Front Load Washer

- 5.8 cu. ft. Mega Capacity
- TurboWash® Technology
- Ergonomic Angled Door for Easier Access
- Full Touch On-Door Control Panel
- Steam Technology
- 15 Cycles / 13 Options
- ColdWash™ Option
- Direct Drive Motor (10-Year Limited Warranty)
- SideKick™ Compatible (WD205CK)
- LG ThinQ® Technology (Wi-Fi)



## LG SIGNATURE



### COLOR AVAILABILITY

- WM9500HKA – Black Stainless Steel

### CAPACITY & MATCHING DRYERS

Capacity (cu. ft.)	5.8
Matching Electric Dryer	DLEX9500K
Matching Gas Dryer	DLGX9501K

### APPEARANCE

Electronic Controls with LED Display	Yes (On Door)
Hard Buttons	Yes
Touch Buttons	Yes

### ENERGY & WATER

ENERGY STAR® Qualified	Yes
CEE Qualified	Advanced Tier
Integrated Modified Energy Factor (IMEF)	2.92
Integrated Water Factor (IWF)	3.2

### WASH CYCLES

Number of Cycles	15
Wash Cycles	Normal, Perm. Press, Heavy Duty, Delicates, Towels, Speed Wash, Rinse+Spin, Bedding, Tub Clean, Bright White, Sanitary, Allergiene™, Jumbowash, Downloaded, Sportswear

### WASH OPTIONS

Number of Options	13
Options	TurboWash®, Steam, Fresh Care, Prewash, Delay Wash, Extra Rinse, ColdWash™, Child Lock, Custom Program, Smart Grid, Wi-Fi Connect / Remote Start, Add Garments, Drum Light

### WASH DETAILS

Internal Heater	Yes
Number of Wash / Rinse Temps	5
Wash / Rinse Temps	Extra Hot, Hot, Warm, Cold, Tap Cold
Number of Spin Speeds	5
Spin Speeds	Extra High, High, Medium, Low, No Spin
Max RPM	1,300
Water Levels	Load Sensing
Number of Soil Levels	5
AAFA Certified	No

### FABRIC CARE

Wash Technology	TurboWash® 2.0
Steam Technology	Yes
Allergiene™ Cycle	Yes
Sanitary Cycle	Yes
ColdWash™ Option	Yes
SenseClean™ System	Yes

### CONVENIENCE

TrueBalance™ Anti-Vibration System	Yes
Dispenser Type	4-Tray (Prewash, Main Wash with Liquid Detergent Cup, Bleach, Fabric Softener)
LoDecibel™ Quiet Operation	Yes
End of Cycle Signal	Yes
LoadSense	Yes
Child Lock	Yes
Auto Suds Removal	Yes
4 Adjustable Leveling Legs	Yes
Easy Loading TiITub™	Yes
ADA Compliant	No

## SMART FEATURES

Wi-Fi Enabled	Yes
ThinQ®	Yes
ThinQ Care	Yes
Voice Control	Google Assistant, Amazon Alexa
SmartDiagnosis™	Yes
Remote Start (On / Off)	Yes
Remote Monitoring & Notifications	Yes

## MOTOR AND AGITATOR

Motor Type	Inverter Direct Drive Motor
Axis	Horizontal

## MATERIALS AND FINISHES

NeveRust™ Stainless Steel Drum	Yes
Door / Rim	Glass / Chrome
Door Cover	Dark Black Tinted Square Cover

## TECHNICAL SPECS

Electrical Requirements	120V, 60 Hz, 10 Amps
Type	Electric
Power Outlet Location	Within 60" of Either Side
Plug Type	3-Prong (Cord Attached to Unit)
Min. / Max. Water Pressure	20 - 120 psi

## INCLUDED ACCESSORIES

Drain Hose, Hot / Cold Water Hoses, Non-Skid Pads, Hole Caps, Wrench, Tie Strap, Elbow Bracket (for Securing Drain Hose)

## OPTIONAL ACCESSORIES

Pedestal	WDP5K
Pedestal (W x H x D)	29" x 13 5/8" x 29 1/2"
LG Sidekick™ Pedestal Washer	WD205CK
LG Sidekick™ Pedestal Washer (W x H x D)	29" x 14 1/8" x 30 7/8"
Stacking Kit	Not Stackable

## DIMENSIONS

Product (W x H x D)	29 5/8" x 41 3/16" x 34 1/16"
Depth with Door Open	56 15/16"
Cutout Dimensions (W x H x D)	31 5/8" x 41 3/16" x 38 1/16"
Carton Dimensions (W x H x D)	31 11/16" x 45 23/32" x 35 3/4"
Approx. Weight (Product / Carton)	239 lbs. / 263.3 lbs.

## LIMITED WARRANTY

Parts and Labor	1 Year
Direct Drive Motor	10 Years (Parts Only)
Drum	Lifetime (Parts Only)

## DIMENSIONS / CLEARANCES

### FLOOR INSTALLATION

To ensure sufficient clearance for water inlet hoses, drain hose and airflow, allow minimum clearances of at least 1 inch (2.5 cm) at the sides and 4 inches (10 cm) behind the washer. Be sure to allow for wall, door, or floor moldings that may increase the required clearances.

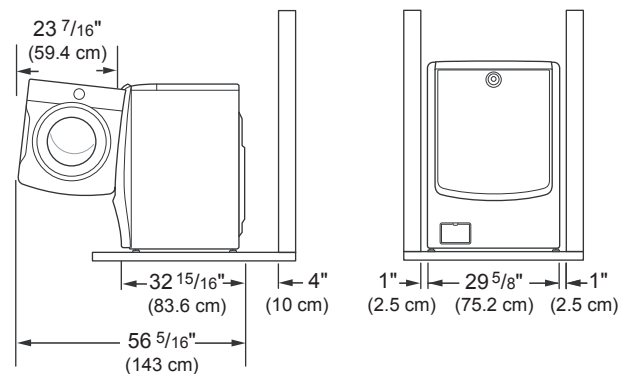

### INSTALLING ON A PEDESTAL

